

NOTES:
1. CLEAN AND DEGREASE PART.

REVISIONS				
ZONE	REV.	DESCRIPTION	DATE	APPROVED

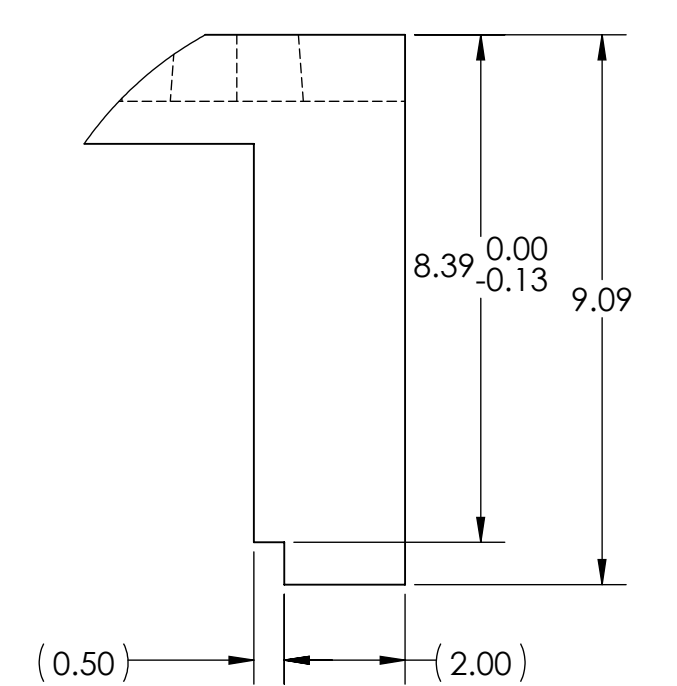
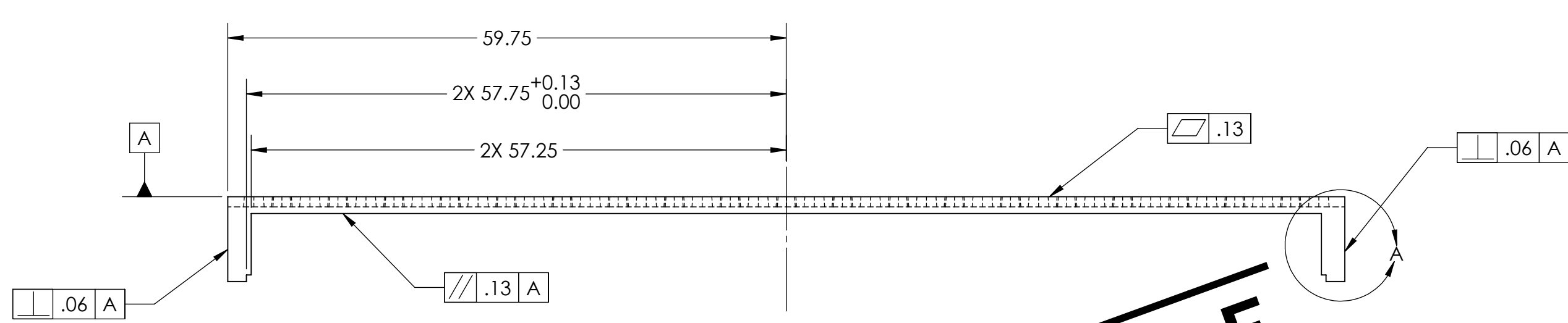
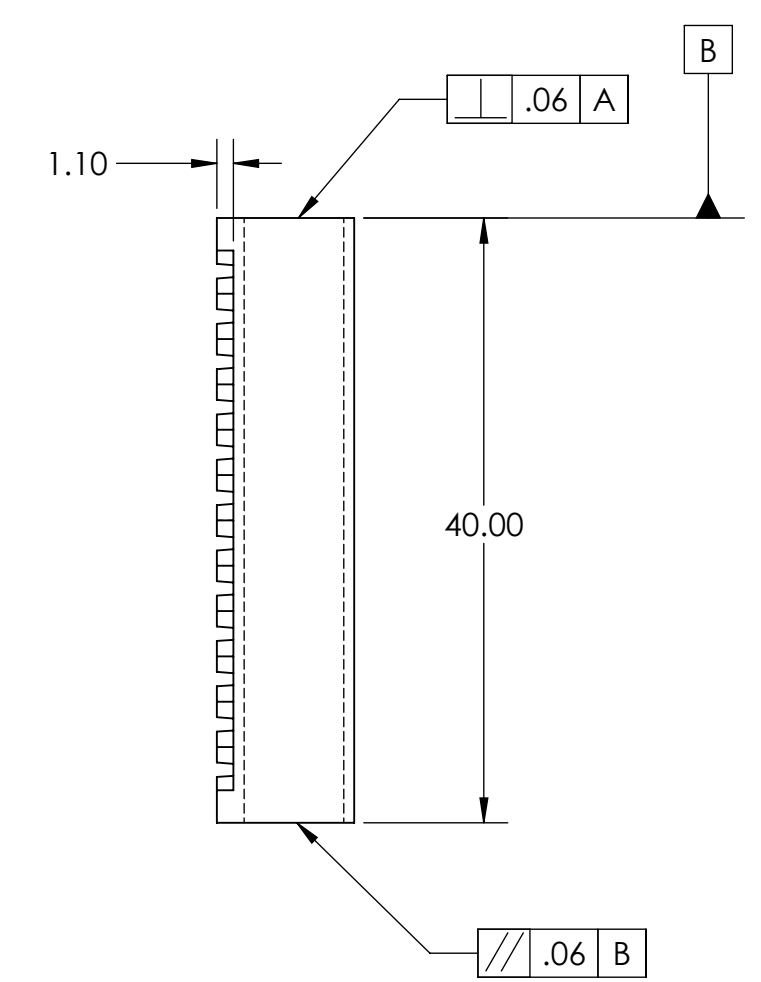
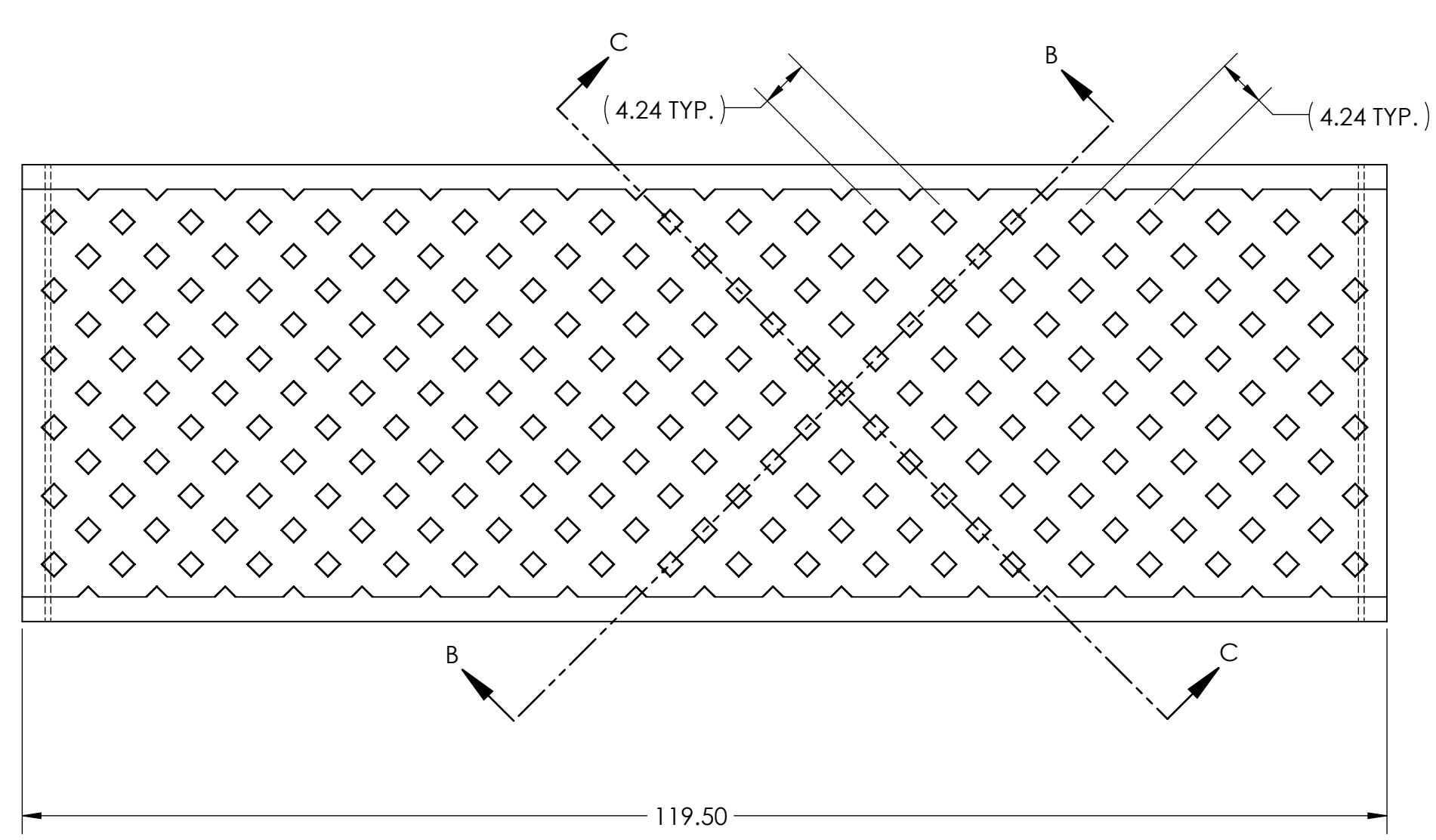

REFERENCE

DRAWING IN ACCORDANCE WITH ANSI Y14.5 STANDARDS 无小数: +/-1.5MM 一位小数: +/-0.4MM 两位小数: +/-0.13MM 角度: +/-1度	GENERAL TOLERANCES (UNLESS OTHERWISE SPECIFIED) LINEAR/RADIAL DIMENSIONS: X ±1.5mm X.X ±0.4mm X.XX ±0.13mm ANGULAR DIMENSIONS: X ±1.0° SURFACE FINISH: - MATERIAL: 3003 Alloy MASS (kg): 0.02 重量0.02 KG	DRAWN BY: ERM DATE: 09-FEB-2016 CHECKED BY: MCS DATE: 15-MAR-2016 ENG APPRV. DATE: MFG APPRV. DATE: QA APPRV. DATE: THIRD ANGLE PROJECTION DOWEL HOLES ±0.050 定位销孔 +/-0.050	材质铝合金3003,锻造加工;祛除毛边毛刺油渍污渍;图纸单位MM,未标注公差见右侧公差表;数量2,136,000件/年,价格需含税运到上海. DESCRIPTION: DIFFUSER, UNIT, TOP 3-1 DRAWING NUMBER: LCDC-R1-0232 DO NOT SCALE DRAWING SCALE: 2:1 ISSUE: A FORMAT: A3 SHEET: 1 OF 2
	COPYRIGHT © 2013 All Rights Reserved	ENGINEERING APPROVAL STAMP	

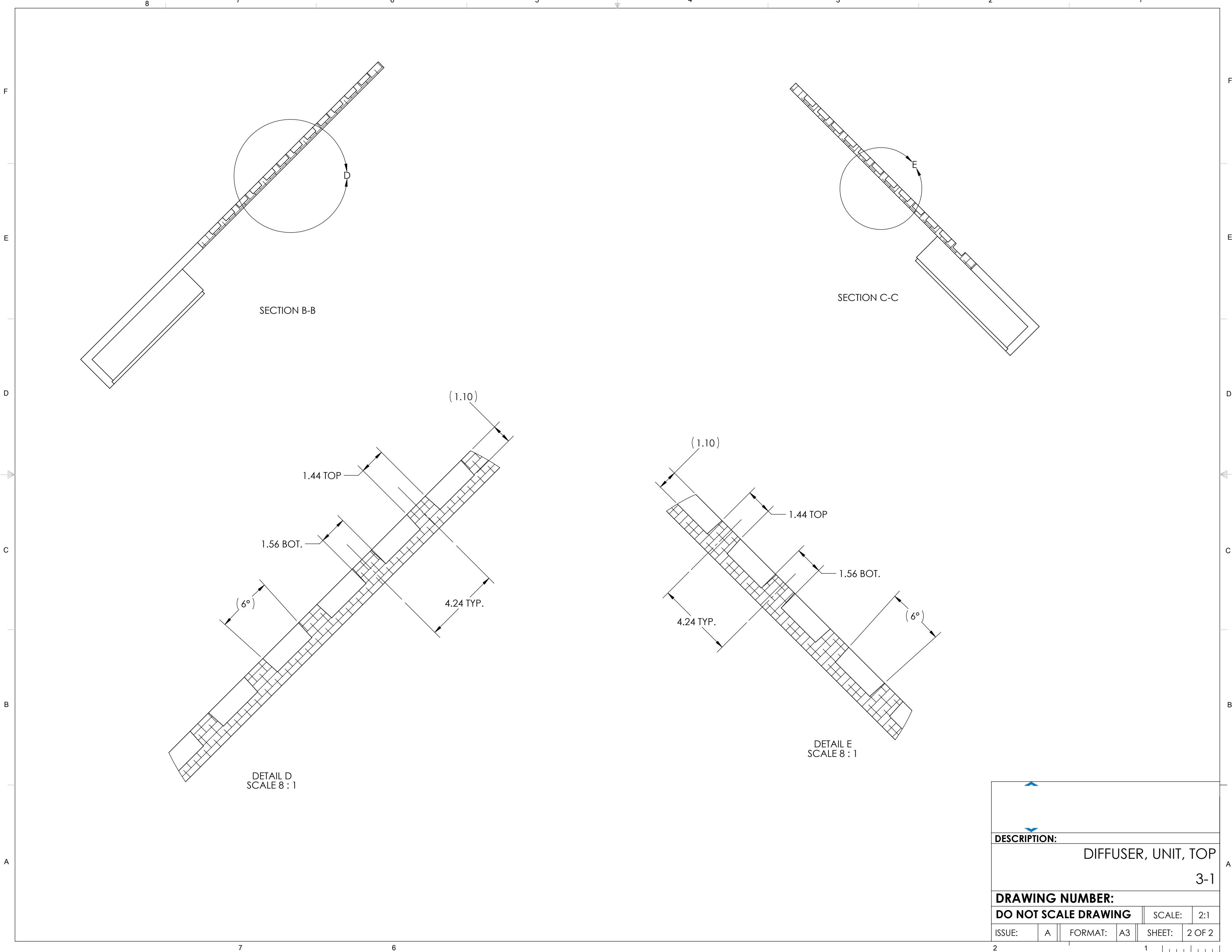

DESCRIPTION:			
DIFFUSER, UNIT, TOP			
3-1			
DRAWING NUMBER:			
DO NOT SCALE DRAWING			
SCALE:	A3	SHEET:	2 OF 2
ISSUE:	A	FORMAT:	A3