

NOTES:

- CLEAN AND DEGREASE PART.
- HOLES ARE ALIGNED WITH OPPOSITE SIDE.

2) 两侧孔位要对齐

REVISIONS				
ZONE	REV.	DESCRIPTION	DATE	APPROVED

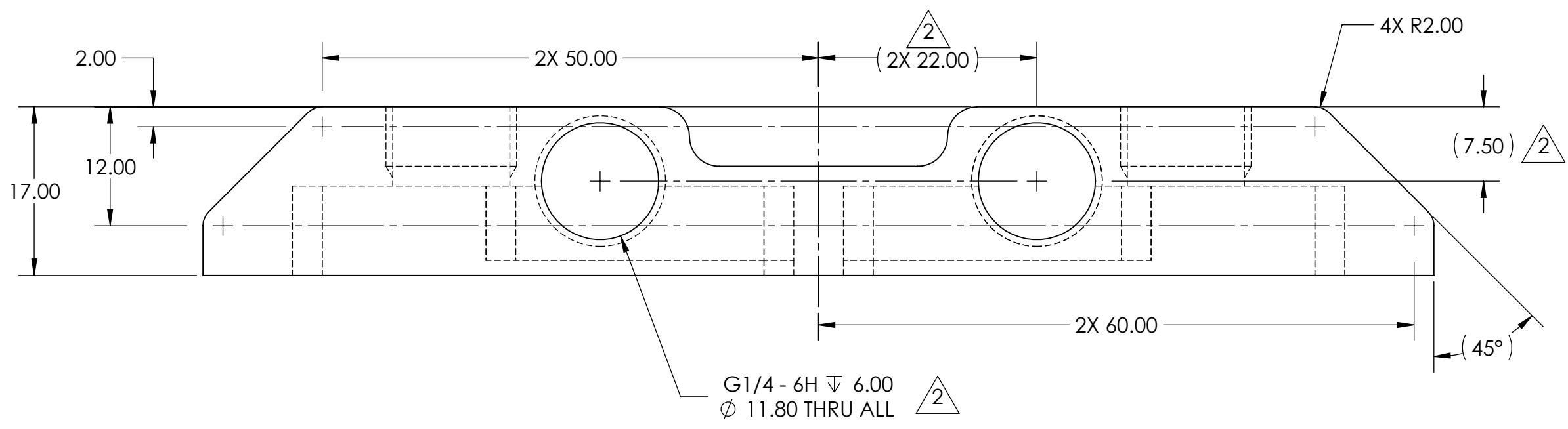
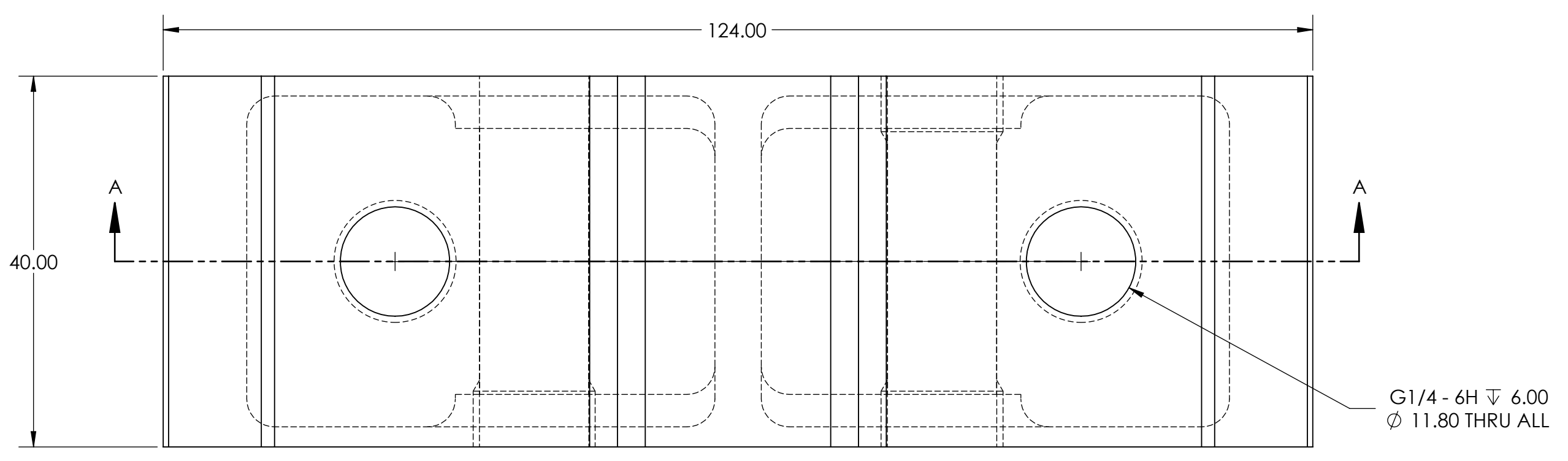
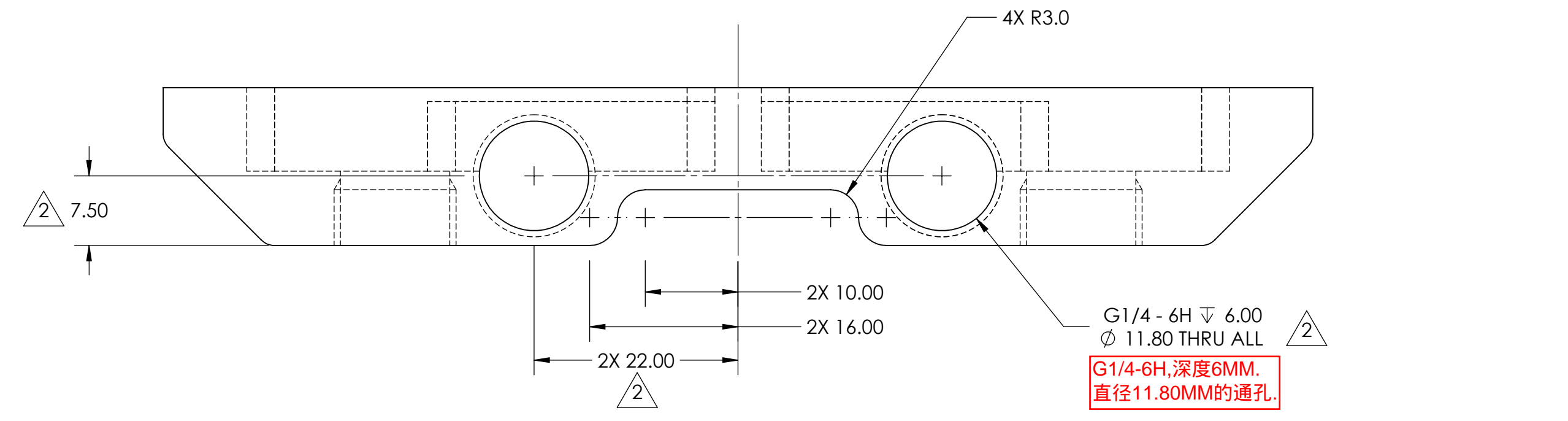

DRAWING IN ACCORDANCE WITH ANSI Y14.5 STANDARDS 无小数: +/-1.5MM 一位小数: +/-0.4MM 两位小数: +/-0.13MM 角度: +/-1度	GENERAL TOLERANCES (UNLESS OTHERWISE SPECIFIED) LINEAR/RADIAL DIMENSIONS: X ±1.5mm X.X ±0.4mm X.XX ±0.13mm ANGULAR DIMENSIONS: X ±1.0° SURFACE FINISH: - MATERIAL: 3003 Alloy MASS (kg): 0.10 重量0.10 KG	DRAWN BY: ERM CHECKED BY: MCS ENG APPRV.: MFG APPRV.: QA APPRV.: THIRD ANGLE PROJECTION DOWEL HOLES ±0.050	DATE: 09-FEB-2016 DATE: 15-MAR-2016 DATE: DATE: ENGINEERING APPROVAL STAMP	材质铝合金3003,锻造加工;祛除毛边毛刺油漆污渍;图纸单位MM,未标注公差见右侧公差表;数量60,000件/年,价格需含税运到上海。 DESCRIPTION: COVER, TOP 3-1 DRAWING NUMBER: LCDC-R1-0238 DO NOT SCALE DRAWING SCALE: 2:1 ISSUE: A FORMAT: A3 SHEET: 1 OF 2	
	COPYRIGHT © 2013 All Rights Reserved	定位销孔 +/-0.050	3	2	1

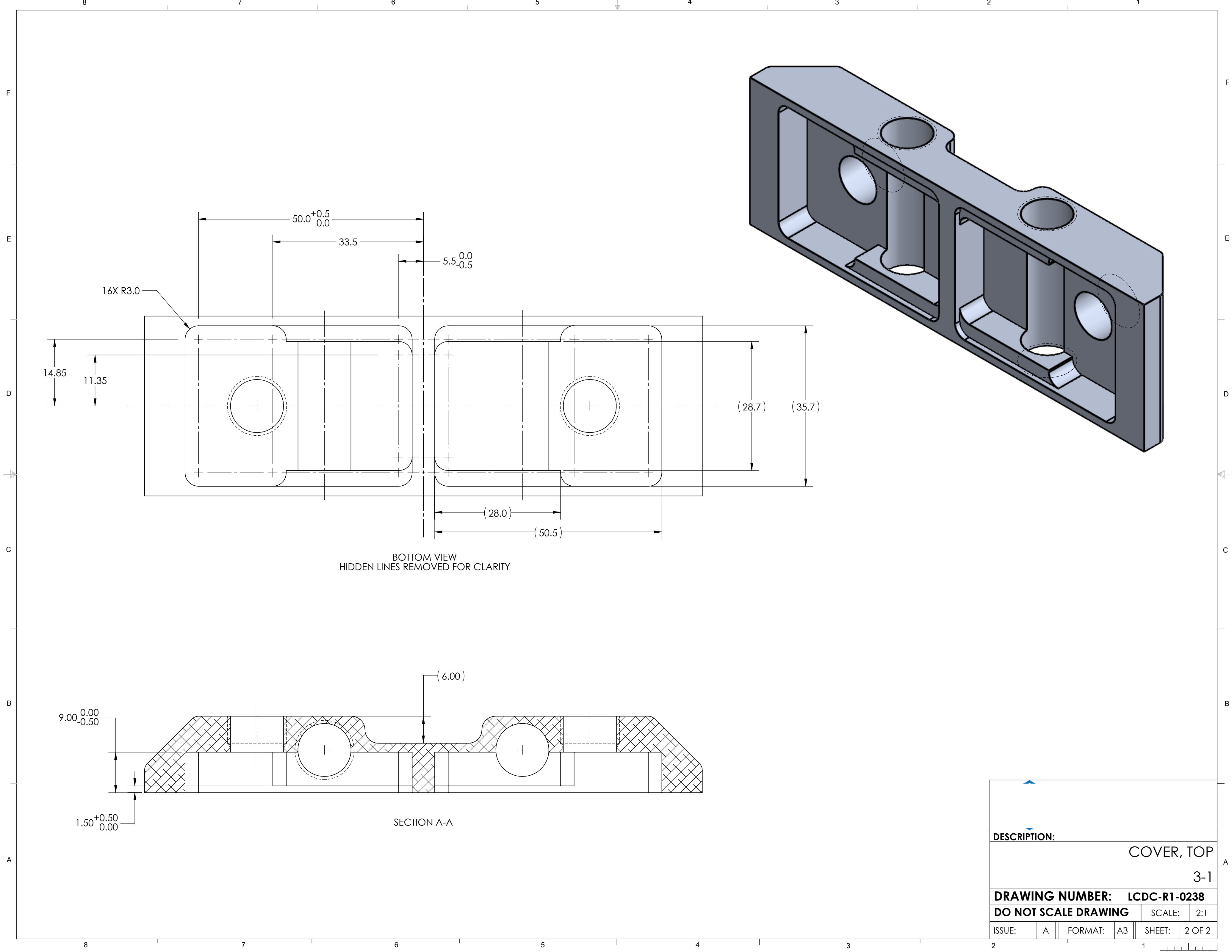

BOTTOM VIEW
HIDDEN LINES REMOVED FOR CLARITY

SECTION A-A

DESCRIPTION:			
COVER, TOP			
3-1			
DRAWING NUMBER: LCDC-R1-0238			
DO NOT SCALE DRAWING			SCALE: 2:1
ISSUE:	A	FORMAT: A3	SHEET: 2 OF 2