

REV.	DESCRIPTION	DATE	APPROVED
------	-------------	------	----------

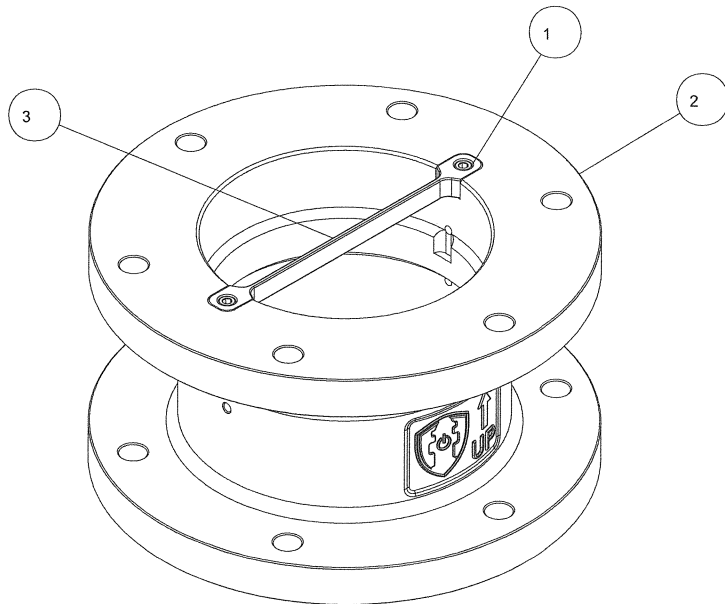
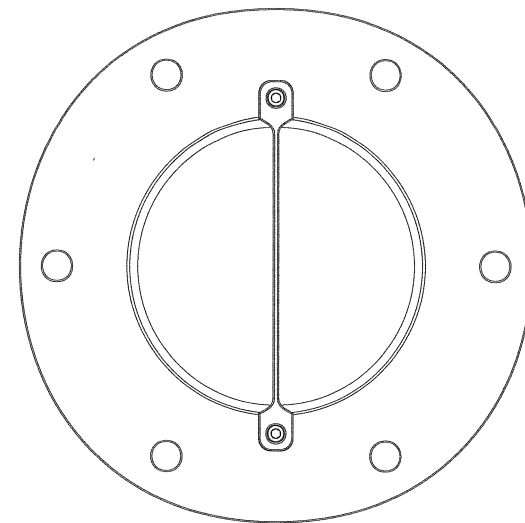
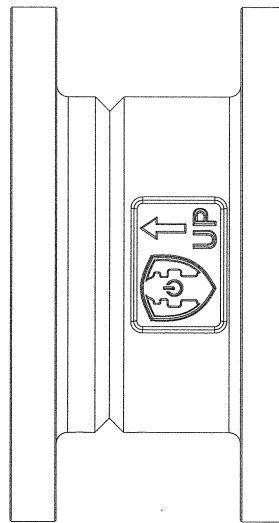
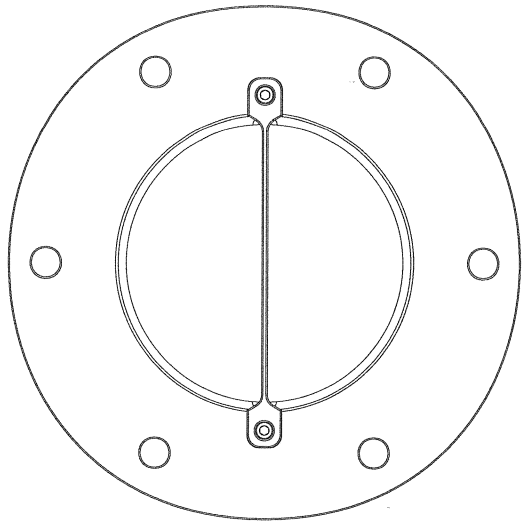

NOTES:

1. ELECTROLESS NICKEL PLATE THIS ASSEMBLY.
2. PLATING THICKNESS TO BE 0.0015" TO 0.002".

QTY	PART NO	DESCRIPTION	MATERIAL	SPECIFICATION	ITEM
2		STABILIZER_BAR			3
1		NECK-MASTER			2
4		92196A317			1

PARTS LIST

UNLESS OTHERWISE SPECIFIED TOLERANCES ON		CONTRACT NUMBER		TITLE	
FRACTION	DECIMAL	ANGLE	DRAFT	DV PLATING ASSEMBLY	
±1/16	.X ±.1	±0°30'	CHGR		
	.XX ±.05		ENGR	SIZE	
	.XXX ±.010		APVD	C	DWG NO
THIRD ANGLE PROJECTION			APVD	REV	
DIMENSIONS ARE IN INCHES			MATL	SCALE:	WT.
				SHEET	OF

DWG NO SH REV

A

REV.	DESCRIPTION	DATE	APPROVED
------	-------------	------	----------

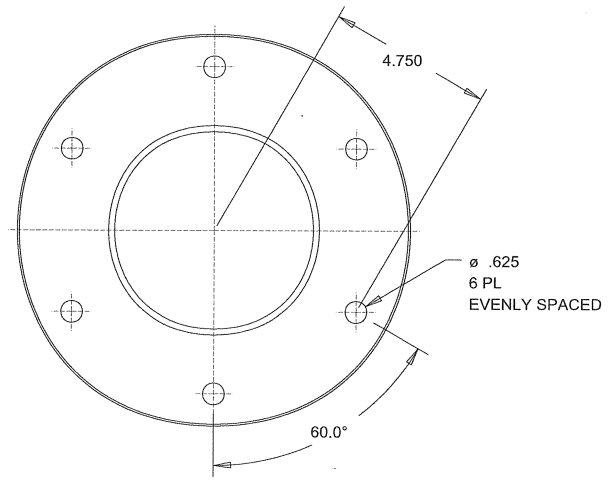
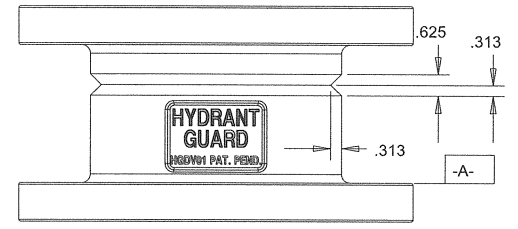
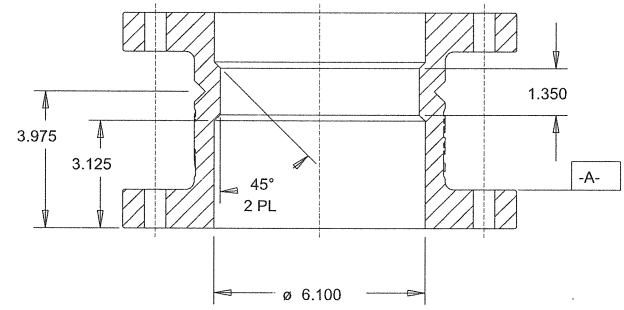
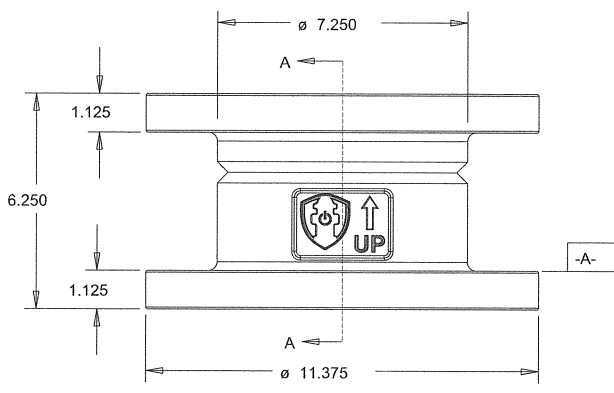
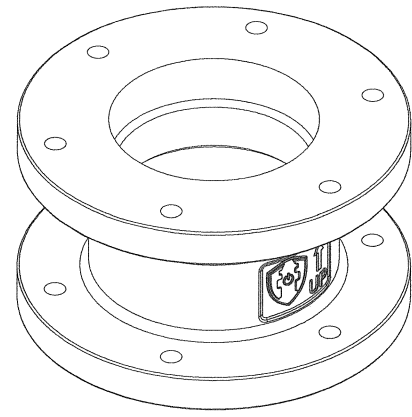
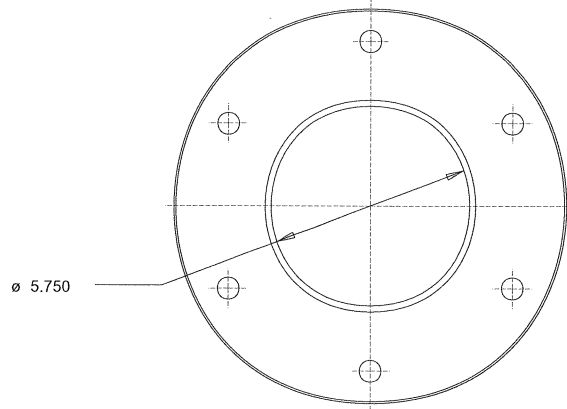

SECTION A-A

QTY	PART NO	DESCRIPTION	MATERIAL	SPECIFICATION	ITEM
PARTS LIST					
UNLESS OTHERWISE SPECIFIED TOLERANCES ON		CONTRACT NUMBER			
FRACTION	DECIMAL	ANGLE	DRFT	TITLE	
$\pm 1/16$	$\pm .01$	$\pm 0^{\circ}30'$	CHKR	NECK CASTING	
	$\pm .005$	$\pm 0^{\circ}30'$	ENGR		
THIRD ANGLE PROJECTION			APVD	SIZE	DWG NO
DIMENSIONS ARE IN INCHES			APVD	C	REV
MATL.			SCALE:	WT:	SHEET OF

DWG NO
SH REV

A

REV.	DESCRIPTION	DATE	APPROVED
------	-------------	------	----------

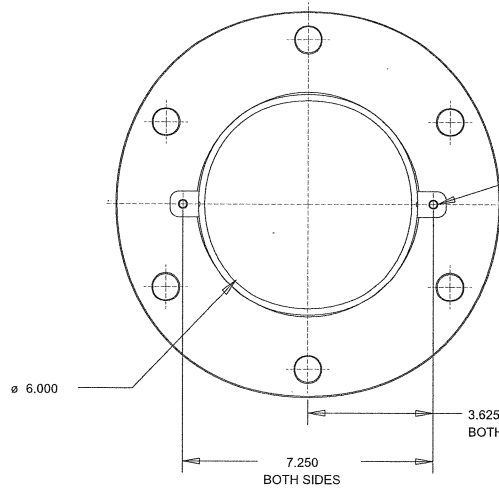

1/4-28 UNF-2b TAP
#3 DRILL (0.213)
BOTH SIDES

▽ 0.375
▽ 0.438 -(2)HOLE

1/4-28 UNF-2b TAP
#3 DRILL (0.213)

▽ 0.280
▽ 0.310 -(1)HOLE
2 PL

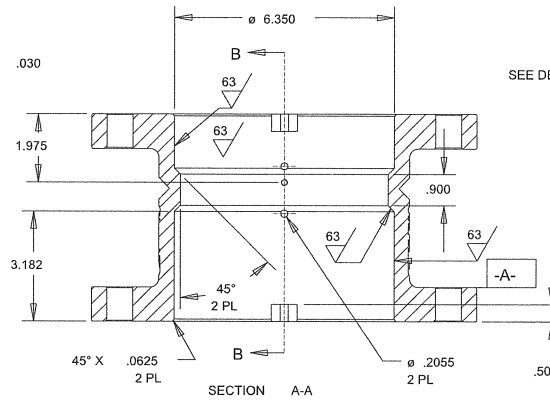
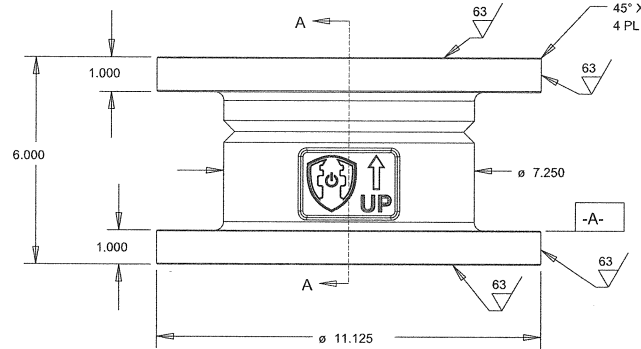
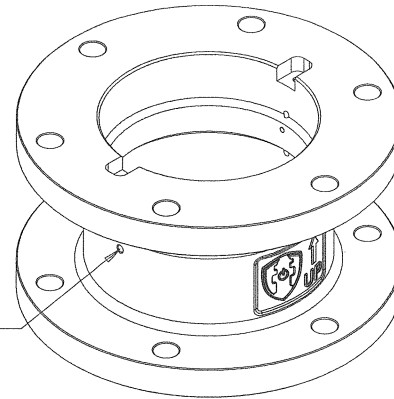

SEE DETAIL

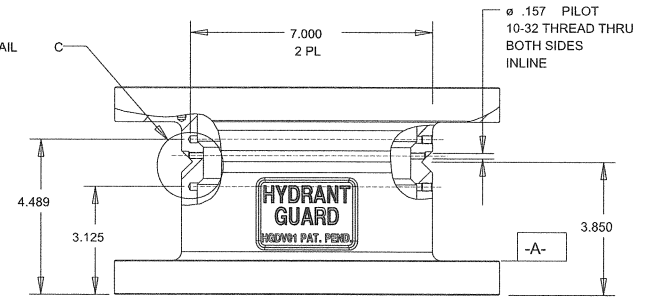

SECTION B-B

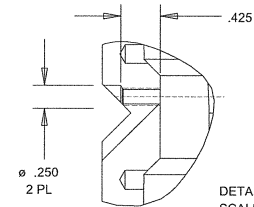

DETAIL C
SCALE 1.000

NOTES:

- BREAK ALL EDGES
- ELECTROLESS NICKEL PLATE ENTIRE BODY AFTER NEXT LEVEL ASSEMBLY.

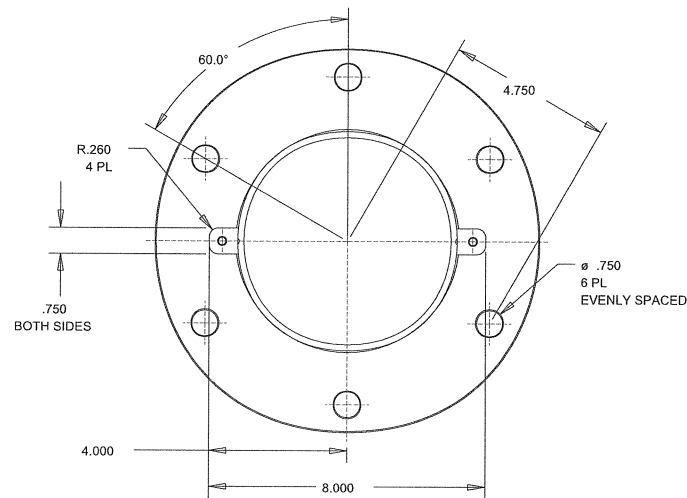

QTY	PART NO	DESCRIPTION	MATERIAL	SPECIFICATION	ITEM
PARTS LIST					
UNLESS OTHERWISE SPECIFIED TOLERANCES ON		CONTRACT NUMBER			
FRACTION	DECIMAL	ANGLE			
±1/16	xx ±.03	±0°30'			
	xxx ±.010				
THIRD ANGLE PROJECTION		TITLE			
DIMENSIONS ARE IN INCHES		NECK-MACHINED-DV			
DRFT	CHKR	ENGR	APVD	APVD	
SIZE C		DWG NO		REV	
SCALE:		WT:		SHEET OF	

DWG NO

A

REV.	DESCRIPTION	DATE	APPROVED
------	-------------	------	----------

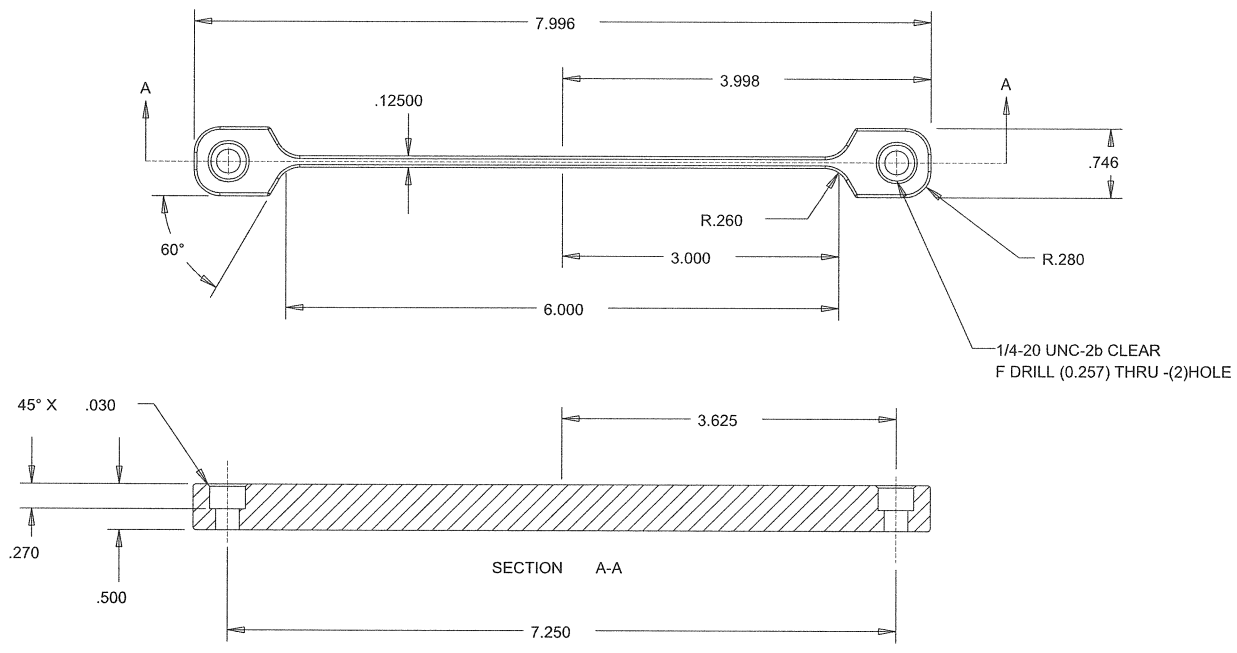

- NOTES:
- BREAK ALL EDGES
 - MATERIAL: 304 STAINLESS STEEL

QTY	PART NO	DESCRIPTION	MATERIAL	SPECIFICATION	ITEM
PARTS LIST					
UNLESS OTHERWISE SPECIFIED TOLERANCES ON		CONTRACT NUMBER			
FRACTION	DECIMAL	ANGLE	DRFT	TITLE	
±1/16	.XX ±.03	±0°30'		STABILIZER BAR	
	.XX ±.03	300° ±.010			
DIMENSIONS ARE IN INCHES		THIRD ANGLE PROJECTION	APVD	SIZE	DWG NO
			APVD	C	REV
MATL			SCALE:	WT:	SHEET OF

REV SH DWG NO

A

REV.	DESCRIPTION	DATE	APPROVED
------	-------------	------	----------

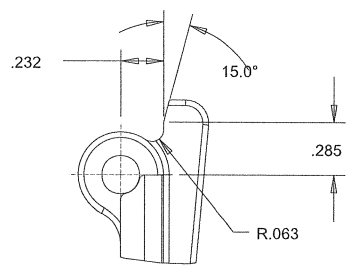
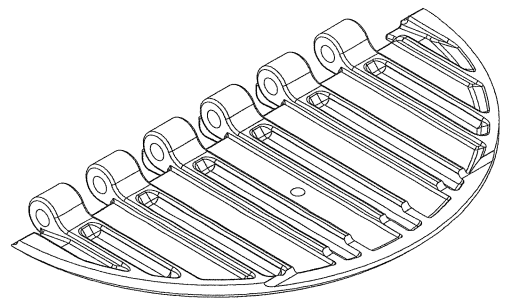

DETAIL A
SCALE 2.000

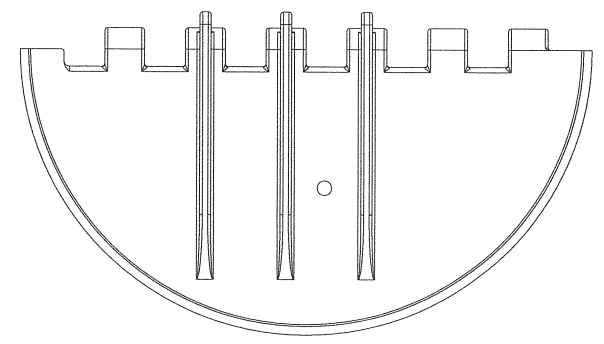
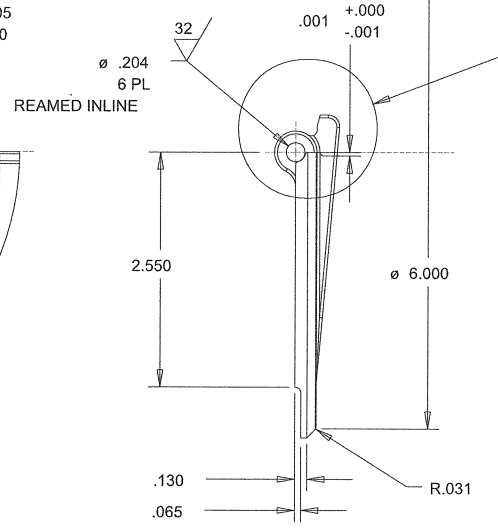
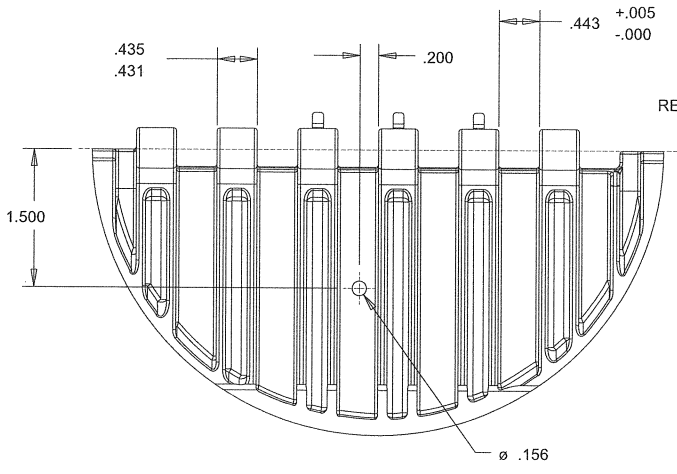

- NOTES:
- BREAK ALL EDGES
 - MATERIAL: USE VALVE PLT BOT CASTING (17-4 PH)
 - HEAT TREAT TO H900 CONDITION AFTER COMPLETING MACHINING.

QTY	PART NO	DESCRIPTION	MATERIAL	SPECIFICATION	ITEM
PARTS LIST					
UNLESS OTHERWISE SPECIFIED TOLERANCES ON		CONTRACT NUMBER			
FRACTION	DECIMAL	ANGLE	TITLE VALVE PLATE BOT		
±1/16	.X ±.1	±0°30'			
THIRD ANGLE PROJECTION		DRFT			
APVD		ENGR			
APVD		SIZE C		DWG NO	
APVD		SCALE:		WT:	
APVD		MATERIAL		SHEET OF	

DWG NO
SH REV

A

1

2

3

4

D

D

C

C

B

A

REV

SH

DWG

NO

A

REV.	DESCRIPTION	DATE	APPROVED
------	-------------	------	----------

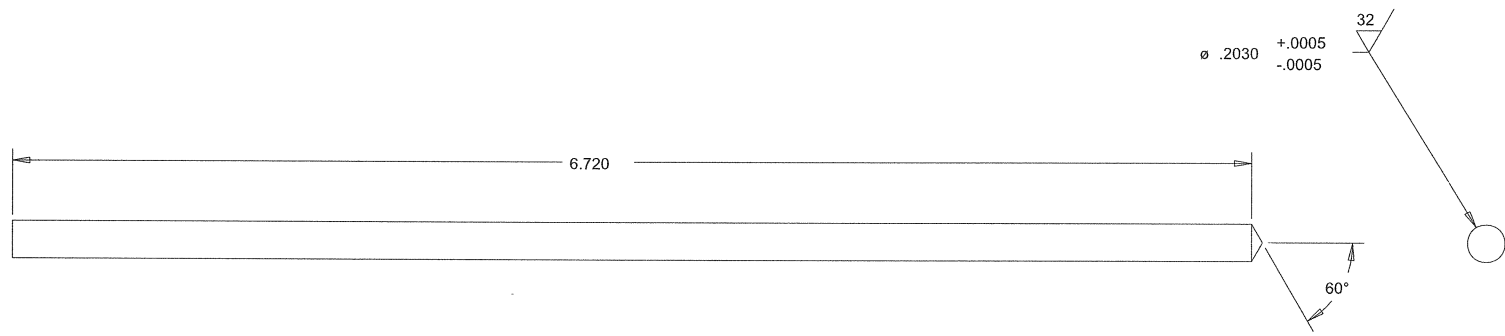

- NOTES:
1. BREAK ALL EDGES
 2. MATERIAL: 17-4 PH STAINLESS STEEL
 3. HEAT TREAT TO H900 CONDITION AFTER COMPLETING MACHINING.

QTY	PART NO	DESCRIPTION	MATERIAL	SPECIFICATION	ITEM
PARTS LIST					
UNLESS OTHERWISE SPECIFIED TOLERANCES ON		CONTRACT NUMBER			
FRACTION	DECIMAL	ANGLE	DRFT	TITLE	
±1/16	.X ±1	XX ±30'	CHGR	HINGE PIN	
	.XX ±.03	XXX ±.000	ENGR		
THIRD ANGLE PROJECTION			APVD	SIZE	DWG NO
DIMENSIONS ARE IN INCHES			APVD	C	REV
MATL			SCALE:		WT:
					SHEET OF

1

2

3

4

1

2

3

4

REV.	DESCRIPTION	DATE	APPROVED
------	-------------	------	----------

D

D

C

C

B

B

A

A

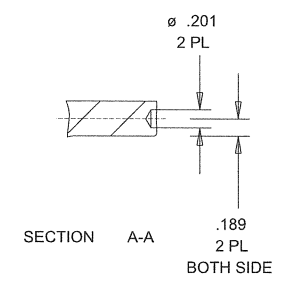
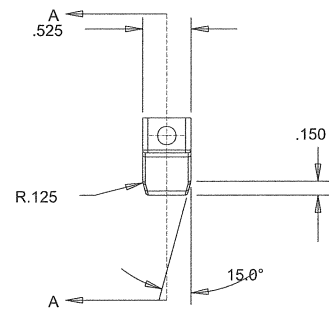
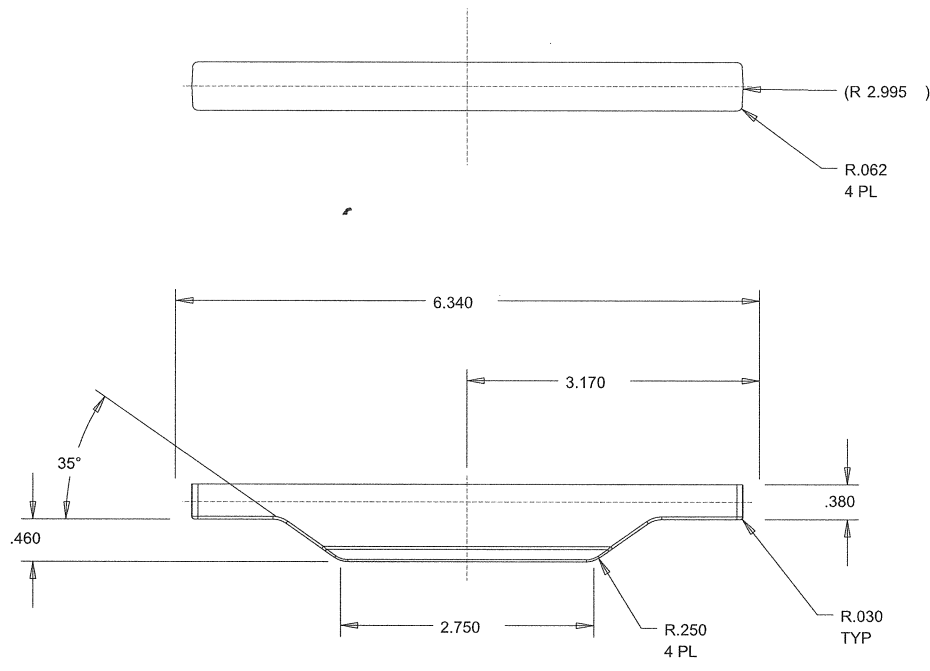

- NOTES:
- BREAK ALL EDGES
 - MATERIAL: ALUMINUM 6061

QTY	PART NO	DESCRIPTION	MATERIAL	SPECIFICATION	ITEM
PARTS LIST					
UNLESS OTHERWISE SPECIFIED		CONTRACT NUMBER			
TOLERANCES ON		TITLE			
FRACTION	DECIMAL	ANGLE	DRFT	KEEPER BAR	
±1/16	.001	±0°30'	CHKR		
	.0005		ENGR		
THIRD ANGLE PROJECTION		SIZE	APVD	DWG NO	REV
DIMENSIONS ARE IN INCHES		C	APVD		
MATL		SCALE:	WT:	SHEET	OF

1

2

3

4

REV SH DWG INC